

## Ultrasonic Applications for Knowles Electret and MEMS Microphones

While in most cases Knowles microphones are used for receiving audible signals, several models are also used in ultrasonic applications. Knowles production line testing typically takes place at several frequencies up to 10kHz. Therefore the microphone specifications are also written with performance data up to 10kHz but not beyond. While this is sufficient for ensuring the quality of the outgoing microphone, it does not mean that the microphone is limited to 10kHz in practice. In this application note typical performance data up to 100kHz is given for the microphone models most commonly used in ultrasonic applications.

### Typical Ultrasonic Applications for Knowles Microphones

- Animal detection (bats, rodents, insects)
- Condition monitoring in machinery
- Non-contact position measurement
- Gesture detection
- Gunshot detection and triangulation

## Popular Microphone Models for Ultrasonic Applications

Although the sensitivity of these microphones is decreasing with frequency above 10kHz, the self-noise is also decreasing so that even at 100kHz the signal-to-noise ratio is high. By taking these response curves into account one can design an amplifier with bandpass characteristics appropriate for the application to maximize signal quality and performance.

Other characteristics may also be important, for example the need for handling high SPL levels or the desire to mount multiple microphones in an SMD array. Whatever the case, Knowles has the microphones to meet your ultrasonic sensing needs.

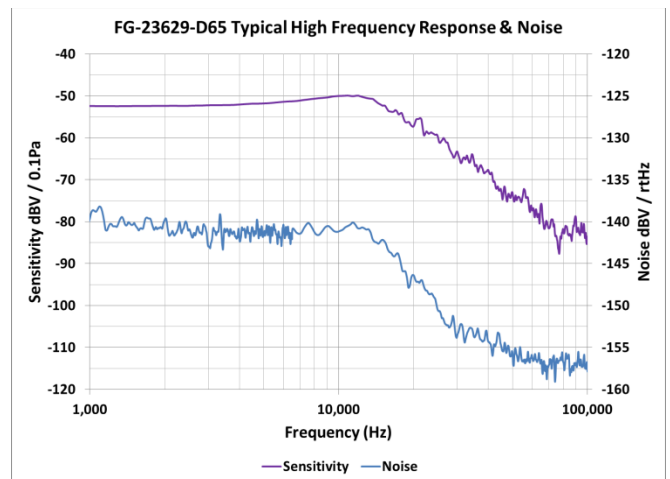

### Model [FG-23629-D65](#)

- Animal detection
- Available with 1m cable
- Ultrasonic and audible pickup in tight spaces

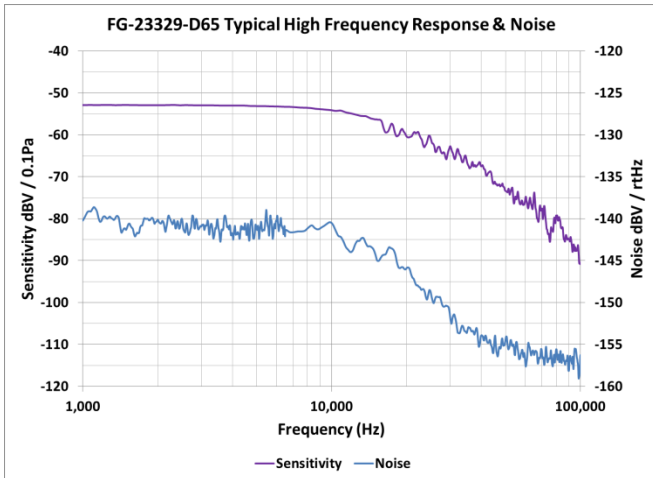

### Model FG-23329-D65

- Animal detection
- Condition monitoring in machinery
- Ultrasonic and audible pickup in tight spaces
- Available with 1m cable

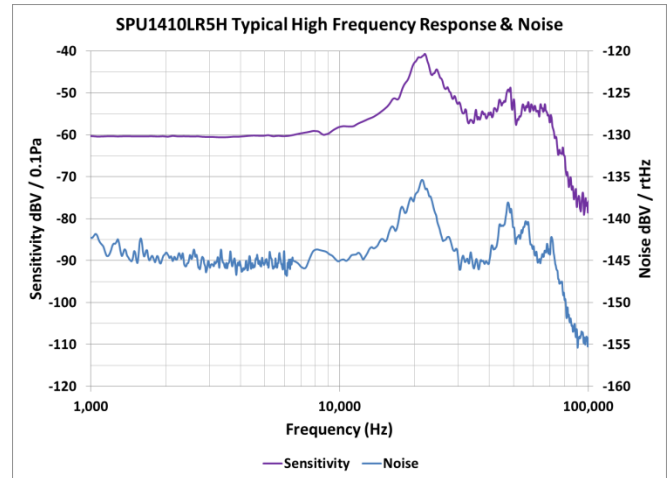

### Model SPU1410LR5H

- Suitable for array applications such as position & gesture detection
- Surface mount component, reflow compatible
- Consistent performance in heat and humidity

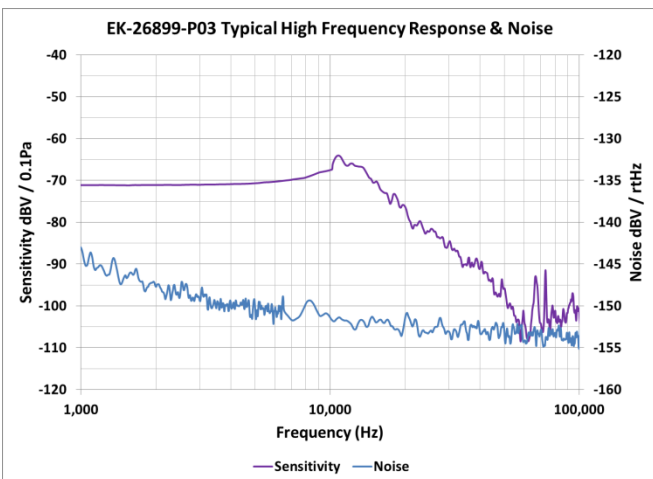

### Model EK-26899-P03

- Linear to 153dB SPL with external headroom circuit
- Gunshot detection and triangulation
- Available in ruggedized & waterproof package

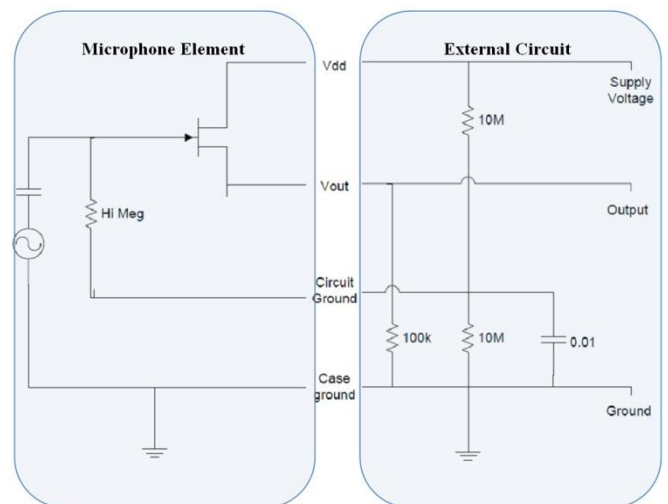

*Optional external headroom circuit for EK-26899-P03  
Maximum 10V supply voltage*